



FEATURES

- This IC can output frequency for being used in the wireless power supply system.
- System Operation frequency is from 50KHz to 500KHz.
- Standby current dissipation 0.1mA when operation voltage under 5V.
- Resonant control is by coil.
- Once the object is identified then this IC will output power by automatic adjustment.
- Provide the protection of power overload and metal sensing.
- LED light indicating the charging activity.
- Provided with the code mechanism by advanced technology and several patent protections.
- Simplified package of QFN-20.
- Function along with $\beta 3$ control IC.

APPLICATIONS

- For electronics product use which power is under 100W.
- Effective sensing distances less than 20mm.
- Wireless power supply system for smart phone and e-book application product.
- Easy to put into mass production by provided application circuit.

TYPICAL APPLICATION CIRCUIT

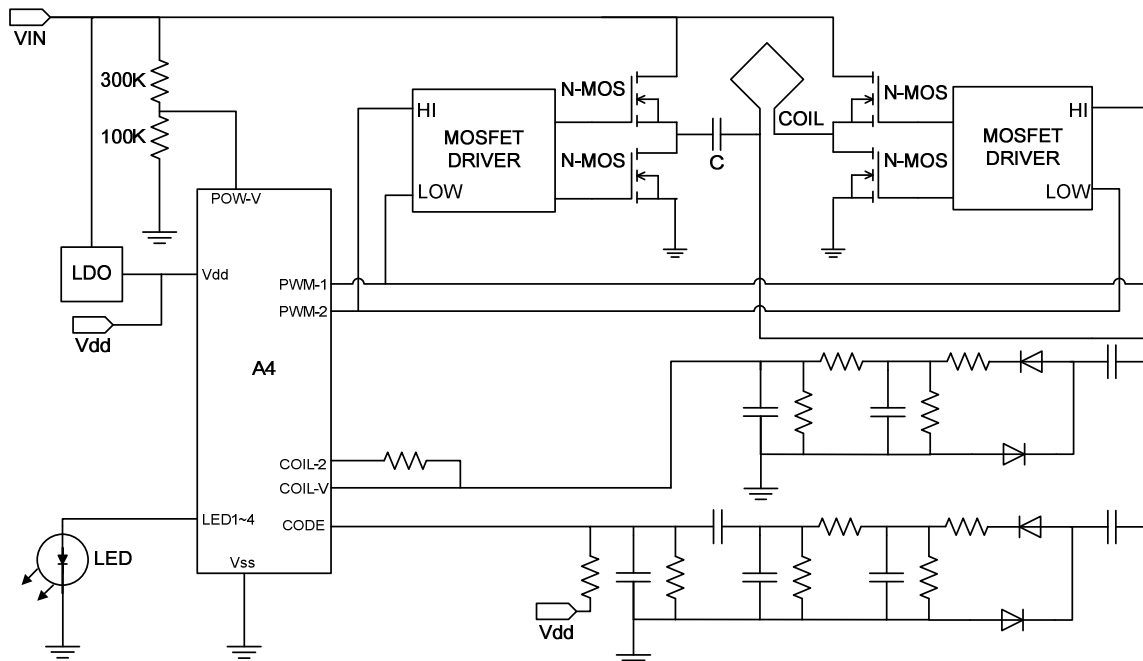

IC PIN FUNCTION

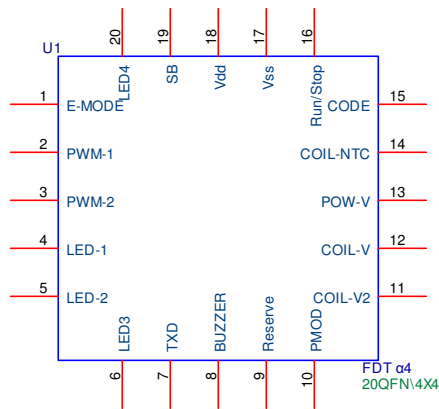

PIN FUNCTIONS

Pin #	Name	Description
1	E-MODE	[Input] Setting operation mode to be normal or analysis. Normal mode : Floating Analysis mode : Ground
2	PWM-1	[Output] Driving source 1
3	PWM-2	[Output] Driving source 2
4	LED-1	[Output] (Red) Indicated led for failed operation
5	LED-2	[Output] (Orange) Indicated led for metal detected
6	LED-3	[Output] (Green) Indicated led for operation status
7	TXD	[Output] UART Port to link with PC
8	BUZZER	[Output] driver buzzer acoustic
9	Reserve	Floating : pull high start up voltage, Ground : normal start up voltage
10	PMOD-S	[Input] Factory setting for metal detected purpose A4 base on external input voltage, like as AC/DC adapter, to set metal detected function to be worked. The procedure is that before turning on external input power, pull this pin to ground. Then turn off power and open to ground.
11	COIL-V2	[Input] The OVP detected of Coil voltage. The max voltage is 4V.
12	COIL-V	[Input] Used for inspecting coil resonant voltage to analyze and adjust automatically the status of coil resonance.
13	POW-V	[Input] Inspecting operating voltage to adjust primary sensing voltage of Rx.
14	COIL-NTC	[Input] Over temperature protection
15	CODE	[Input] Analyze information code from Rx for distinguishing objects to adjust automatically.
16	Run/Stop	[Input] Run / Stop mode Run mode is floating and stop mode is pull down to ground.
17	Vss	[Input] Ground

18	Vdd	[Input] Power Input pin
19	SB	[Input] Show Battery capacity
20	LED-4	[Output] (Blue) The indicated led for the status of receiver

ABSOLUTE MAXIMUM RATINGS

Parameter	Value		Units
	Min	Max	
Working environment temperature	-40	+125	°C
Storage temperature	-65	+150	°C
Relative voltage of Vdd pin to Vss pin	-0.3	+6.5	V
Relative voltage of other pins to Vss pin	-0.3	Vdd+0.3	V
Largest input current of Vdd		800	mA
Largest output current of Vss		80	mA
Largest output current of other pins		25	mA

ELECTRICAL CHARACTERISTICS

Parameters	Symbol	Condition	Min	Typ	Max	Units
Operating Voltage	Vdd	Standard ⁽¹⁾	3.5	5	5.5	V
Supply Current (Standby)	I	Standard ⁽¹⁾		0.3	1	mA
Supply Current (In operation)	I	Standard ⁽¹⁾		12	15	mA
Pull High Current	I _{ph}	Vdd=5V		100	200	μA
Power-Up Timer	Powtmr			100	180	mS

⁽¹⁾ Design for typical use of circuit

Marking Details



● : Pin 1 indicator

FDT : Fa Da Tong Technology

α4 : A4 TX, Product Name

YYWW : Date code



MSL Results To J-STD-020C Profile Pass MSL1/260C

ORDERING INFORMATION

Part Number	Package	Top Marking	Free Air Temperature (TA)
FDT-A4TX-QFN20	QFN20 (4*4mm)	FDT α4	- 40°C TO + 125 °C

PACKING INFORMATION

Part Number	Package	Packing	Single Purchase Quantity
FDT-A4TX-QFN20	QFN20 (4*4mm)	TAPE & REEL	3000 PCS

OPERATION

Vdd & Vss

Vdd and Vss are not only used to support IC power, but the both pins are reference pins. Each voltage levels of system are refer to them. Therefore, the stable is more important. We advice to put a ceramic capacitor 0.1Uf(104) to filter noise from external power source. It had better near close to between Vdd and Vss. A4 can accept low voltage range 3.5~5V in order to also support battery source.

POW-V

This pin is a A/D converter pin for detecting external power voltage. We need place external divider resistors on it and please refer the typical application circuit in page 1. The high side resistor is 300K Ω and low side resistor is 100K Ω . POW-V can accept 0.875~4V. By the external standard divider resistors, the input range voltage of transmitter will be 3.5~16V. Once input power higher than max. voltage, the system will stop and LED1 will turn on. Another side, if input power is lower than min. voltage, the system will stop in off status.

COIL-V & COIL-2

The both pins are used to detect the DC voltage from resonance coil. After A4 get the voltage, A4 will analysis to optimize PWM-1 AND PWM-2 to keep operation.

COIL-NTC

For over temperature protection, external NTC 10K Ω @25 $^{\circ}$ C could be placed between COIL-NTC to ground. This function should enable by setting PMOD process.

CODE

A4 get response signal of receiver from CODE pin via filter circuit t. The DC level of CODE should keep below 2V.

PWM-1 & PWM-2

There are two drivers on A4 chip to work half-bridge or full-bridge circuit. PWM-1 and PWM-2 are inverse phase.

LED-1 & LED-2 & LED-3 & LED-4

Display the status of operation

LED-1 (Default is Red) Fail indicated

- A. If led is flash, it means the input voltage is higher and make POW-V great than 4V.
- B. If led always on, it means the current circuit is detected fail and do not work.

LED-2 (Default is orange) Metal object detected indicated

- A. If led is flash, it means metal object is detected and almost to stop operation.
- B. If led is always on, it means the system have detected metal object and stopped operation.

LED-3 (Default is green) Power indicated led of TX board

- A. If led flash, it means TX is ready to operate and do not detect RX signal yet.
- B. If led always on, not only standby normally but TX board has had metal detected function.

LED-4 (Default is blue) Indicated led for on transmitting

- A. If led flash, it means TX have detected response signal from RX.
- B. If led always on, not only operate normally but TX board has had metal detected function.

Show Battery display

After pulling down Show Battery (PIN19) to ground, A4 will base on the below voltage scale to show the current input voltage on the four leds.

LED-1 Flash, below 3.8V

LED-2 Flash, 3.8V~4.0V

LED-3 Flash, 4.0V~4.2V

LED-4 Flash, 4.2V~4.6V

Four LED always on, above 4.6V,

TXD

FDT provide communication software to link A4 to PC. We advice to prepare a USB-TO-RS232 cable. A4 send out internal critical data to PC. Those data is useful to R/D, QA and factory member to keep quality.

E-MODE

Operation setting. This pin is floating normally and the status will enter factory mode.

PMOD-S

Enable the metal object detected. This pin does not need to pull down to ground in normal use, but setting metal object function.

Setting step :

1. First, make sure no any metal object above the transmitting coil and all component is around 25 °C .
2. Pull down PMOD-S to ground
3. Decide the value of input voltage and turn on to support TX board.
4. During setting procedure, LED1~LED4 will turn on one by one. It is almost need two second.
5. Once LED3 (Green) turn on, this setting procedure is done and successful.

Run/Stop

Setting pin for the status of operation in run or stop. Floating is normal to run and pull to ground is to stop. The power consumption is below 0.1mA.

Show Battery

Setting pin for display of battery capacity. Floating is un-used and pull to ground is to display.

Buzzer

Drive buzzer to sound. Twice beep is normal and one beep is abnormal.

PACKAGE INFORMATION

4x4x0.9 mm Body –QFN 20-Lead Plastic Quad Flat, No Lead Package

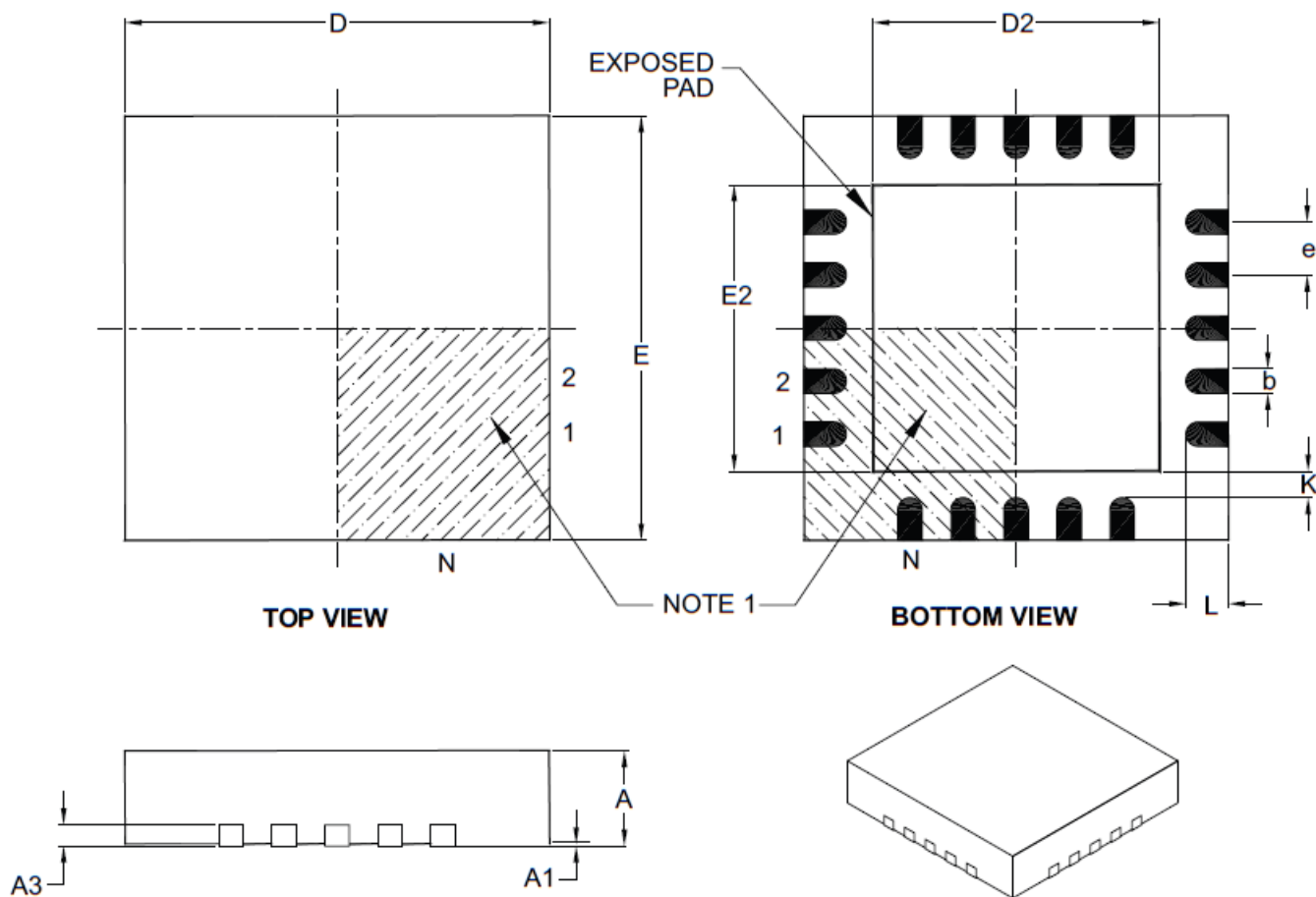

Dimension Limits	Units	MILLIMETERS		
		MIN	NOM	MAX
Number of Pins	N	20		
Pitch	e	0.50 BSC		
Overall Height	A	0.80	0.90	1.00
Standoff	A1	0.00	0.02	0.05
Contact Thickness	A3	0.20 REF		
Overall Width	E	4.00 BSC		
Exposed Pad Width	E2	2.60	2.70	2.80
Overall Length	D	4.00 BSC		
Exposed Pad Length	D2	2.60	2.70	2.80
Contact Width	b	0.18	0.25	0.30
Contact Length	L	0.30	0.40	0.50
Contact-to-Exposed Pad	K	0.20	–	–

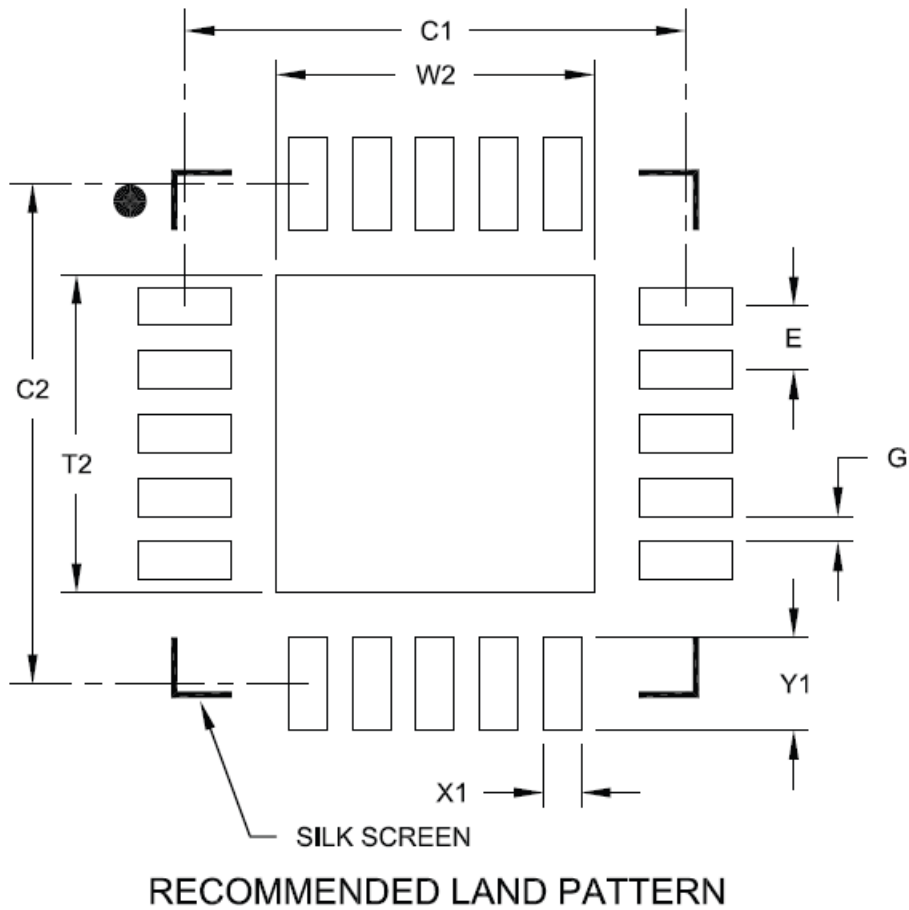

		Units	MILLIMETERS		
Dimension		Limits	MIN	NOM	MAX
Contact Pitch	E		0.50 BSC		
Optional Center Pad Width	W2				2.50
Optional Center Pad Length	T2				2.50
Contact Pad Spacing	C1			3.93	
Contact Pad Spacing	C2			3.93	
Contact Pad Width	X1				0.30
Contact Pad Length	Y1				0.73
Distance Between Pads	G		0.20		

TAPE & REEL

Package			Carrier Dimensions		Cavity Dimensions			Units per Reel	Reel Diameter mm
Type	Width/Size	Leads	W mm	P mm	A ₀ mm	B ₀ mm	K ₀ mm		
QFN	4x4x0.9mm		12	8	4.35	4.35	1.1	3300	330

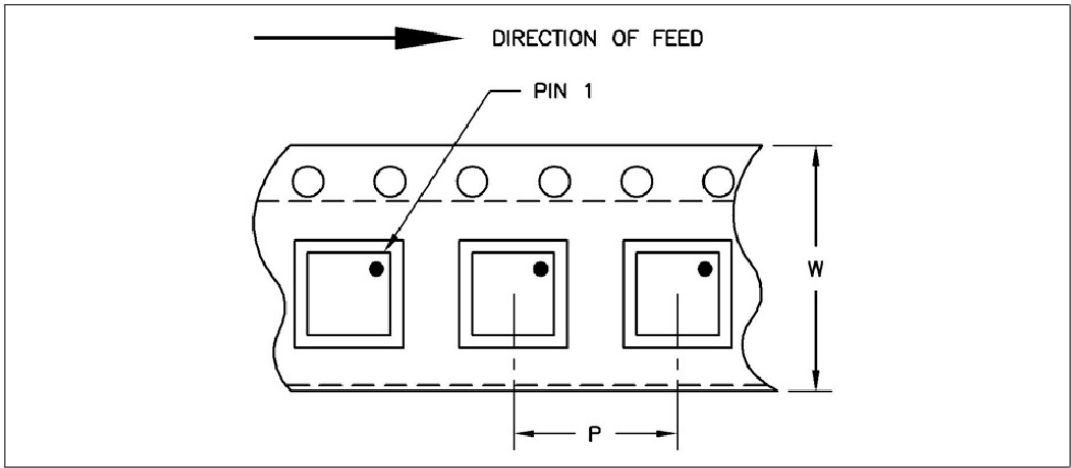

Reflow process

FIGURE 1: Sn/Pb TYPICAL REFLOW PROFILE

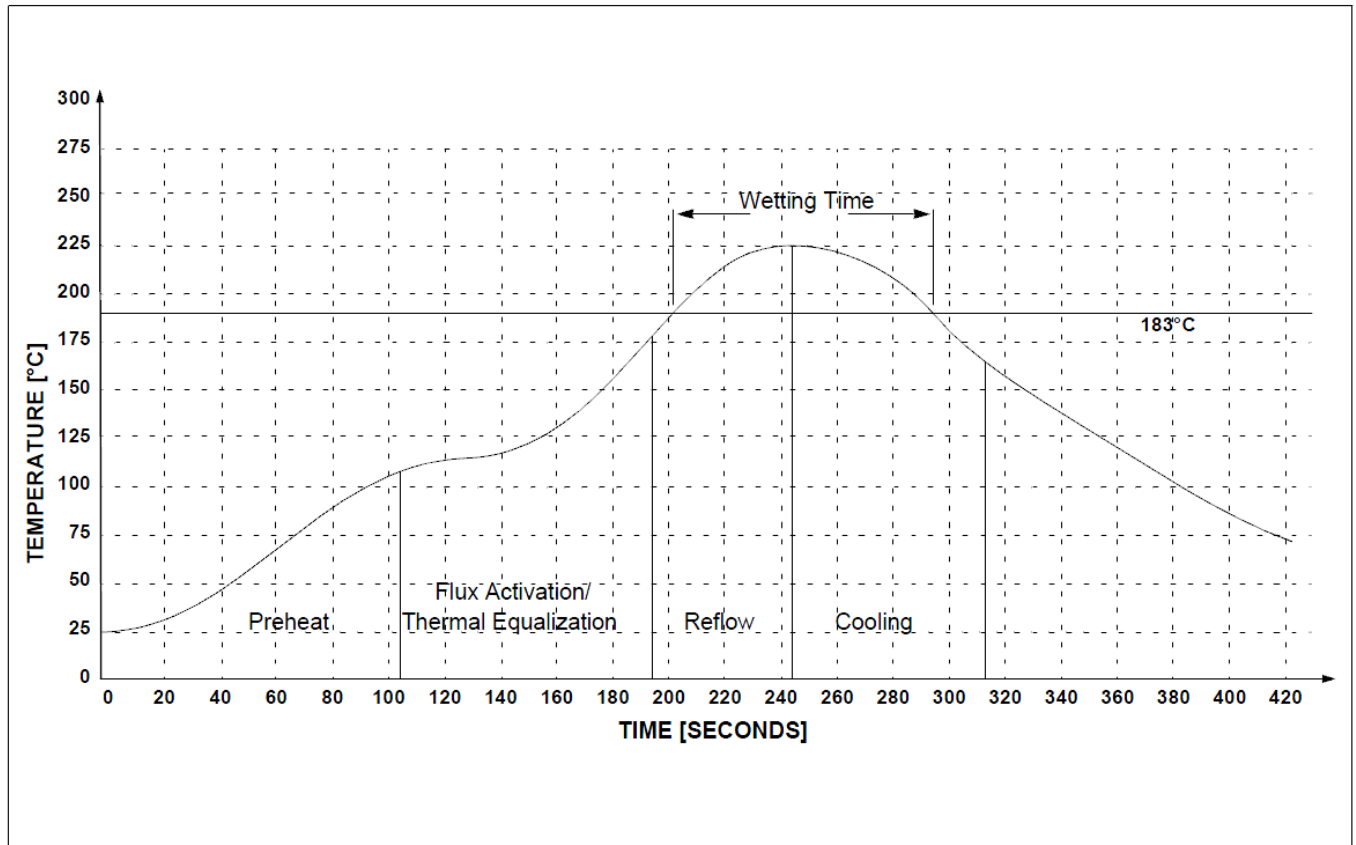

FIGURE 2: JEDEC REFLOW PROFILES FOR Sn-Pb AND Pb-FREE ASSEMBLIES

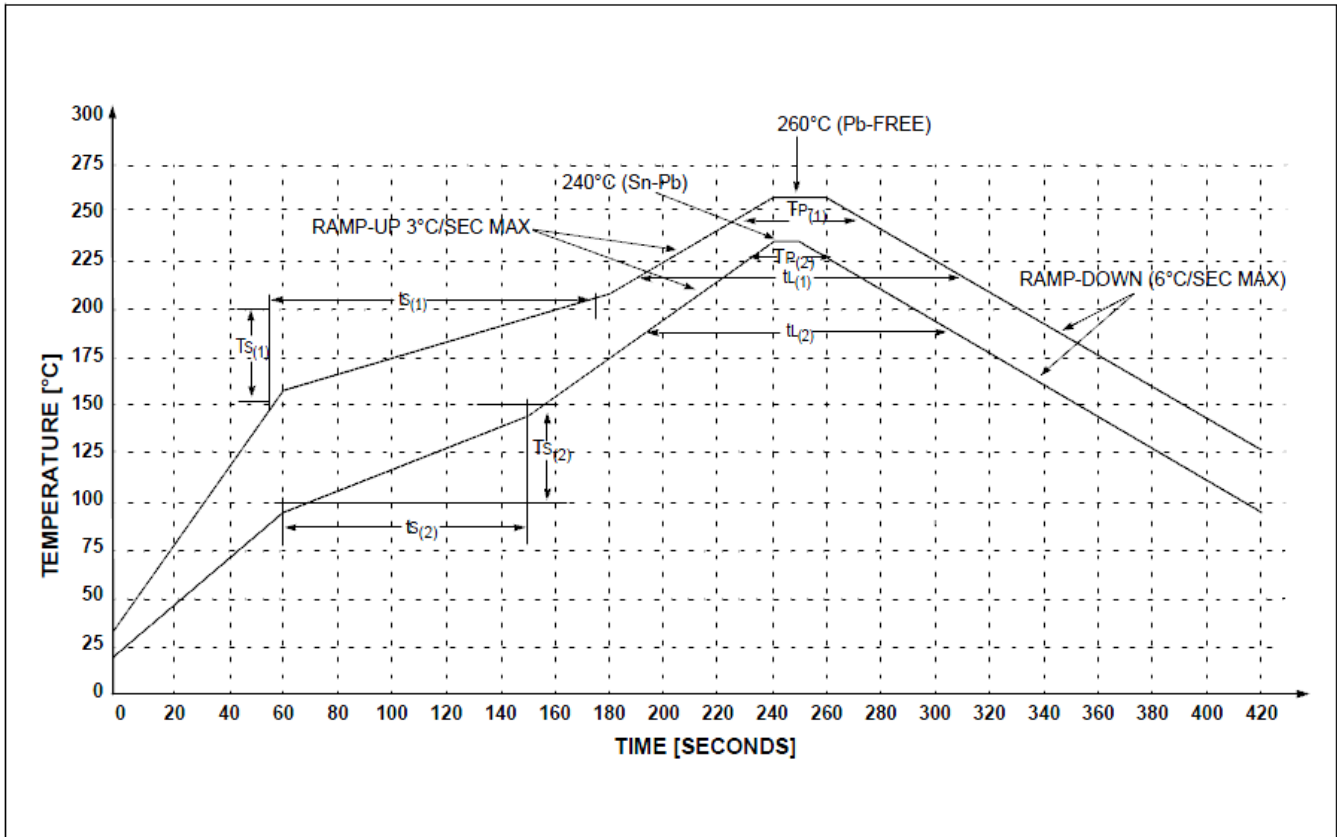

TABLE 1: TIME AND TEMPERATURE PARAMETRICS

Sym.	Min.	Max.	Units	Test Conditions
$T_{s(1)}$	150	200	°C	Pb-Free
$T_{s(2)}$	100	150	°C	Sn-Pb
$t_{s(1)}$	60	180	Sec	Pb-Free
$t_{s(2)}$	60	120	Sec	Sn-Pb
$t_{l(1)}$	60	150	Sec	Pb-Free
$t_{l(2)}$	60	150	Sec	Sn-Pb
$T_{p(1)}$	245	260	°C	Pb-Free
$T_{p(2)}$	225	240	°C	Sn-Pb

For reference, reflow conditions from IPC/JEDEC J-STD-020C are reproduced in Figure 2 and Table 1.

FIGURE 3: REFLOW PROFILE RECOMMENDATION (Pb-FREE)

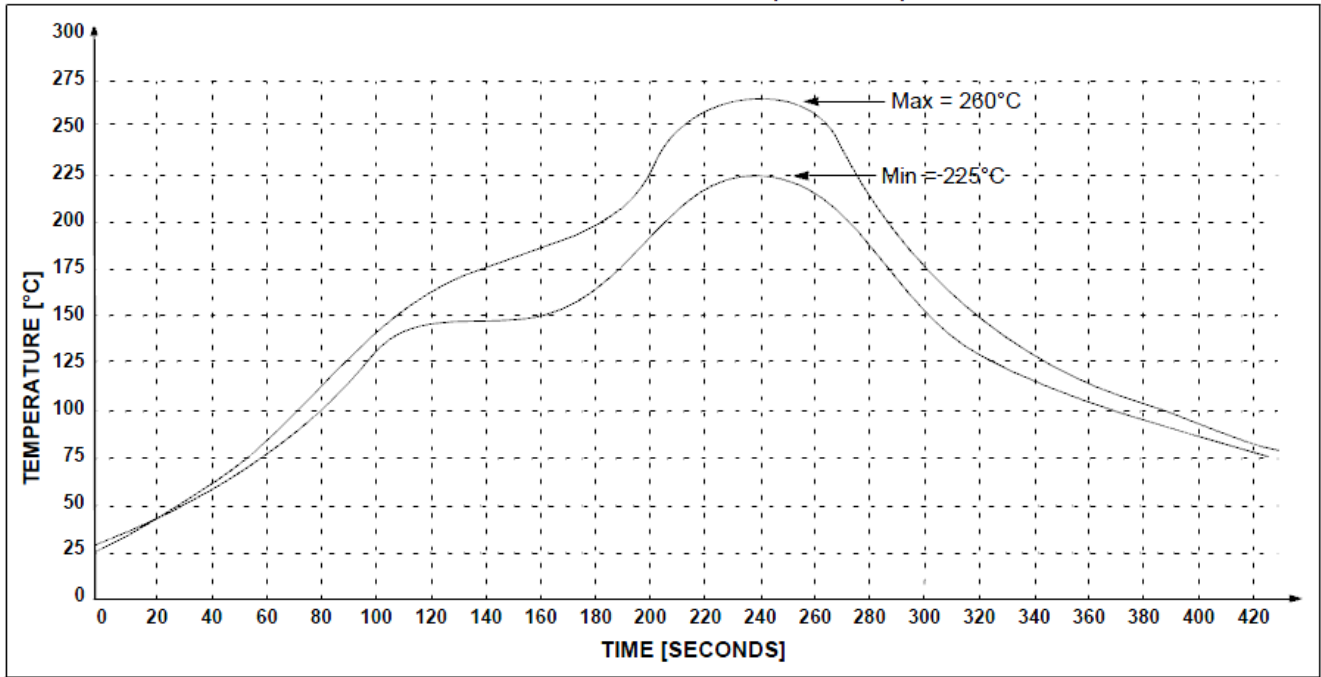
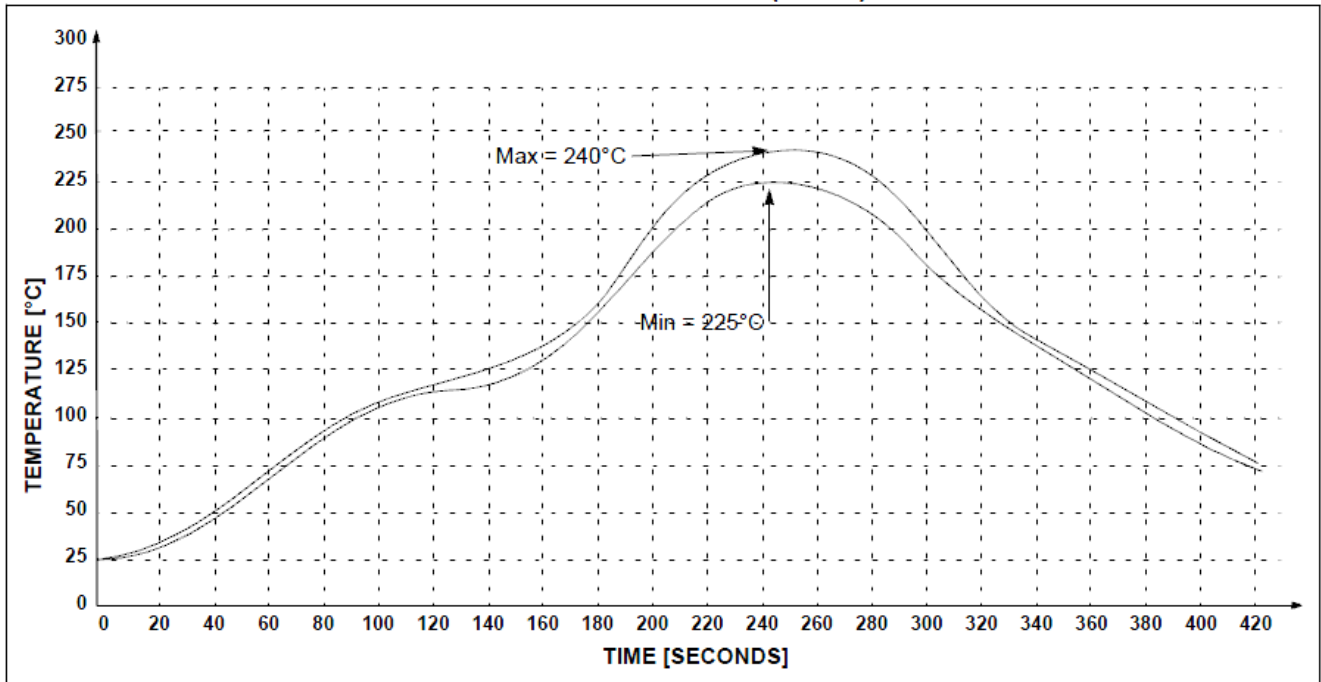
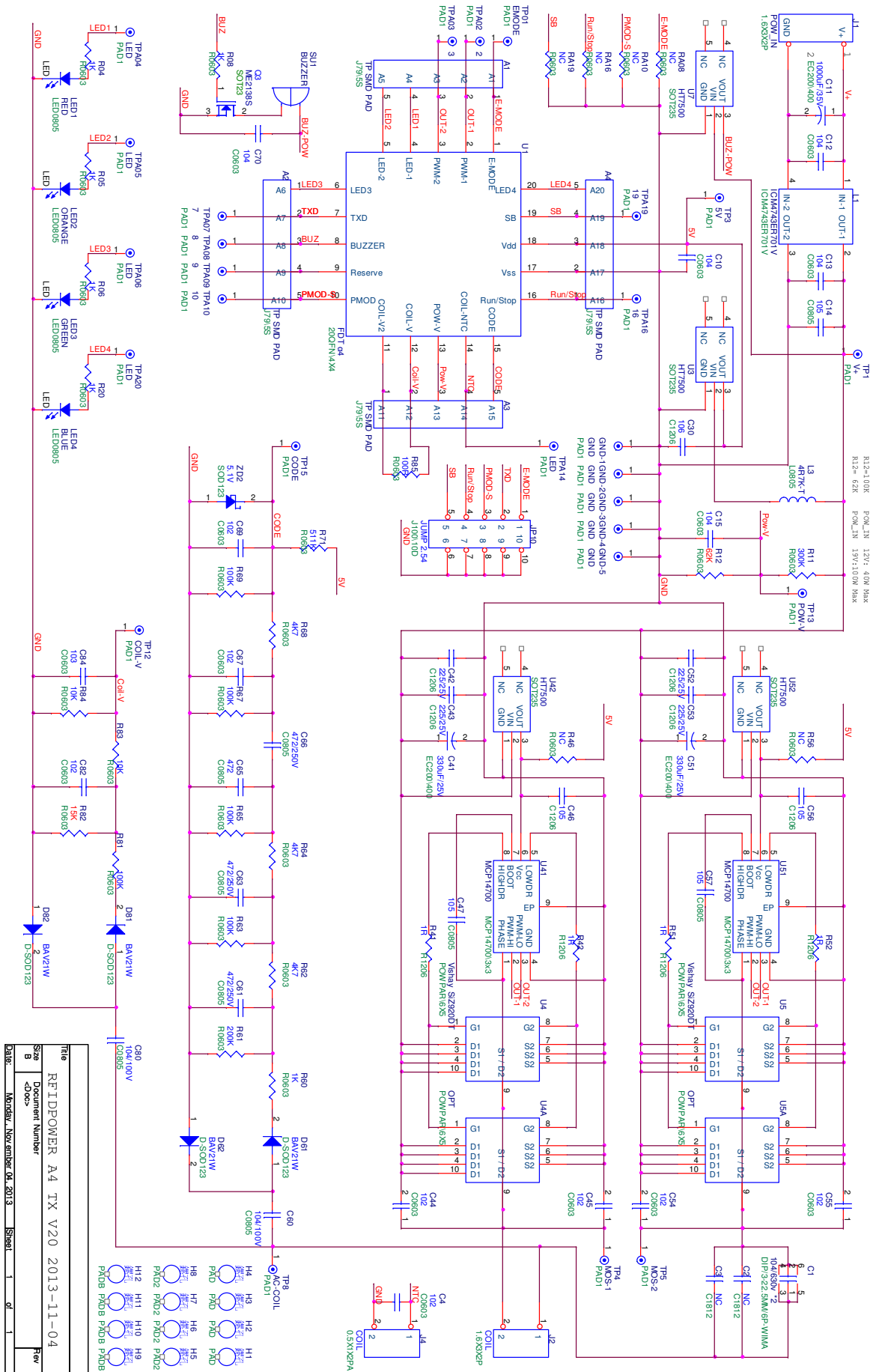

FIGURE 4: REFLOW PROFILE RECOMMENDATION (Sn/Pb)



Reference schematic



Title	Rev
R1DPPOWER_A4_TX_V20_2013-11-04	1
Document Number	
Size	
B	
Date:	Monday, November 04, 2013 5:01 PM

Recommended coil design and capacitance

The theory of wireless charging system transmitting and receiving wireless charging power is based on the coil inductance and capacitance resonance. The resonant frequency is been decided by both coil and capacitance, which are the key to the system operation. IC α 4 has been designed by advanced technology of adjusting resonant frequency automatically. However, when designing products, developers still need to set resonant frequency in reasonable range to let the system work.

At the start of designing wireless charging system, coil design is the first step. Next, with the setting of capacitance, the operating frequency should be in appropriate range.

Capacitor is common product, and its capacity increases or decreases fractionally. Hence, the suggested selection of capacitance is shown in the table below. The specification is common in the market. As shown in the table, the recommended resonant frequency is between 90KHz and 110KHz since the system will be most stable.

There may be different inductances between Tx coil and Rx coils, but the resonant frequencies of Tx and Rx can be set the same by fitting various capacitances. With this design, the system will work at best efficiency.

The technique of automatic adjusting of IC α 4 will allow system working under the condition of 20% differences of resonant frequencies between Tx and Rx. Nonetheless, the optimal design is still the same resonant frequencies of these two coils.

The table below is coil and capacitance cross-reference. After the completion and inductance measurement of coil, please refer to the table finding suitable capacitance. The best value of coil inductance will be between 10 μ H and 20 μ H.

Operation Code Table

Code	Description
FF	Normal operation

Code_Notice	Description
E1	Notice code : Code is not complete.
E2	Notice code : The first trigger code is lost.
E3	Notice code : Signal is not complete and can not start up.
E4	Notice code : Decode rate is low.
E5	Notice code : Rx is in sleeping mode.
E6	Notice code : System is on OSC Calibrate mode.
E7	Notice code : Output power is on the mass level.
E8	Notice code : The coil voltage is over on battery driving mode.

Code_Metal detected	Description
D1	Notice code : TX detected metal object, but don't change indicated LED.
D2	Notice code : TX detected metal object and change indicated LED.
D3	Notice code: Temperature is high

Code_Abnormal_pin	Description
11	Abnormal code : 11_COIL-V2 abnormal
12	Abnormal code : 12_COIL-V abnormal
13	Abnormal code : 13_POW-V abnormal
14	Abnormal code : 14_NTC abnormal
15	Abnormal code : 15_CODE abnormal

Code_Abnormal	Description
31	Error code : The voltage of POW-V rise up too fastly.
32	Error code : The voltage of POW-V drop down too fastly.
33	Error code : Resonance coil or driver circuit abnormal.
34	Error code : Coil voltage is abnormal.

35	Error code : POW-V voltage is too high.
36	Error code : POW-V voltage is too low.

Fu Da Tong (FDT) Technology

WWW.RFIDPOWER.COM.TW

10F.-5, No.880, Zhongzheng Rd., Zhonghe Dist.,

New Taipei City 23586, Taiwan (R.O.C.)

FAE@RFIDPOWER.COM.TW

JIANG@ESTCORP.COM.TW